

GARAGE DOOR OPERATOR USER'S MANUAL

(FBC180 / FBC200)

OUTLINE

1. Safety instructions.....	3
2. Main features	3
3. Technical specifications	4
4. Check	4
5. Installation and adjustment	4
6. Programming	8
7. External terminal connections	14
8. Maintenance	15
9. Troubleshooting	15

1. Safety instructions

Carefully read and follow all safety precaution, warnings before attempting to install and use this garage door operator, incorrect installation can lead to severe injury.

- The installation should be carried out by a qualified technician.
- To avoid electrical shock, disconnect the power cord from the mains power outlet before doing any repairs or removing the cover.
- The door operator must be grounded.
- Before installation of the door operator, the door should be carefully checked for being kept well balance. The door must be in good working order. Open and close the door manually, make sure the door can be moved smoothly.
- No one or vehicle is allowed to enter or leave the garage while the remoter is being installed, do not allow children to play near the door.
- Locate any fixed control: within sight of door but away from all moving parts of the door and at a height of more than 1.5m above the ground to avoid children reaching it.
- Keep remote controls away from children, to prevent the door operator from being activated involuntarily.
- When opening or closing the door, do not attempt to walk or drive through the door.
- The door should only be operated when it can be observed to avoid accidents.
- Install and adjust the manual release so that the handle hangs less than 1.5m above the floor.
- Our company reserves the right to change the design and specification without prior notification.

Failure to comply with the instructions above may result in personal injury or property damage. Our company does not accept responsibility for damage or injury resulting from installing this operator.

2. Main features

- The door operator is designed for garage door.
- The control unit regulates all the necessary functions such as automatic lighting control, automatic memory, automatic close, automatic reverse and photocell protection etc., extremely quiet and smooth operation.
- Courtesy light will turns on in using and turns off after 3 minutes.
- The operator memorizes the limit positions and unique braking system that slows the unit down at the end of its travel. Soft start and soft stop control guarantees extremely smooth and quiet operation.
- Automatic reversion on obstruction during closing procedure.
- The controller has a security LOCK function which prevents operation of the door from transmitter.
- In the event of power failure, the release device makes it possible to open and close the door manually.
- Smart controller and encoder system. Hopping code remote control with max. 20 pcs hand transmitters.
- Battery, button switch and infrared photocell are optional.

3. Technical specifications

Model	FBC180	FBC200
Motor power	80 W	100 W
Lifting capacity	800 N	1000 N
Max. door size	12 m ²	16 m ²
Power supply	220X(1± 10%)V AC 50-60Hz	
Motor	24VDC	
Ambient temperature	-20° C~+50° C	
Working humidity	≦ 90%	
Courtesy light time	3 minutes	
Radio frequency	433.92 MHz	
Transmitter type	Rolling code	
Transmitter battery	27A 12V	
Bulb	24V 5W	

4. Check

After receiving the product, you should make an unpack-inspection, in which you should check whether the product was damaged. If you have any problem please contact dealer.

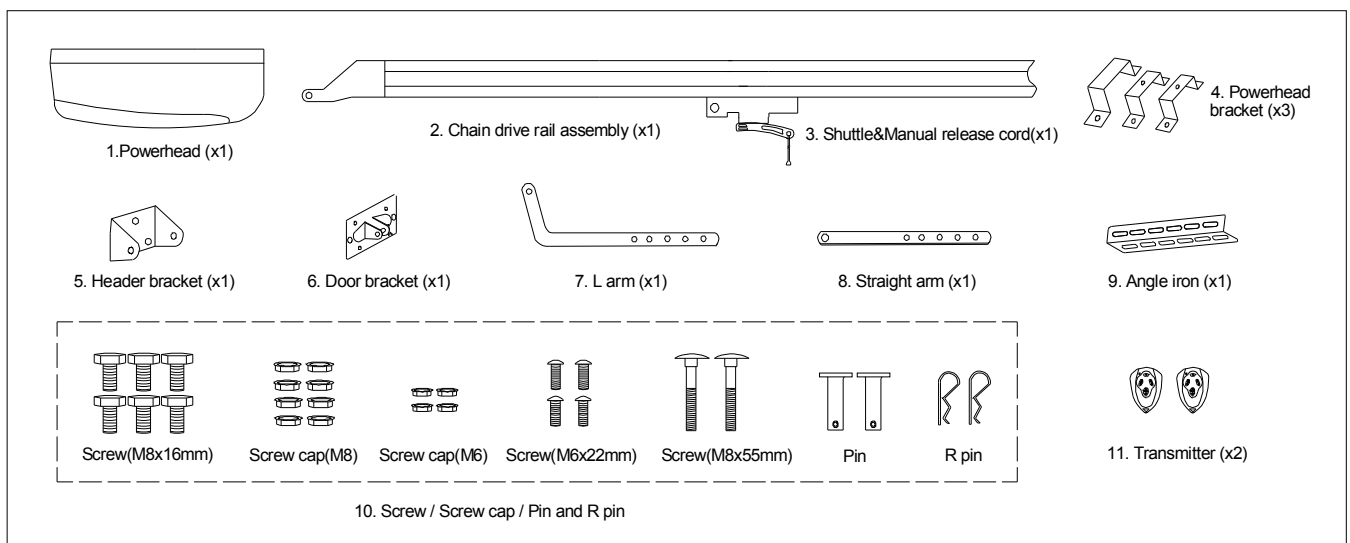

Fig.1

5. Installation and adjustment

Step1

- Check the door is in good working condition, manually open and close the door to make sure the door operates smoothly and freely.
- The door must be well balanced.
- Check to see if there is a solid frame in the wall above the center of the door.
- Close the door.
- Measure the door width, mark the centerline of the door using a pencil, and extend the line down to the door surface, then up the wall above the door.
- Check the installation height of the operator. Slowly open garage door and observe the

highest point of door while moving. Close the door again and mark this highest point on the wall, mark a horizontal line across the vertical centerline around 40mm above the highest point. (Note: there should be 80mm space between this horizontal line to the ceiling. If there is not enough space, please use the max. height possible to allow the header bracket to be fitted properly.)

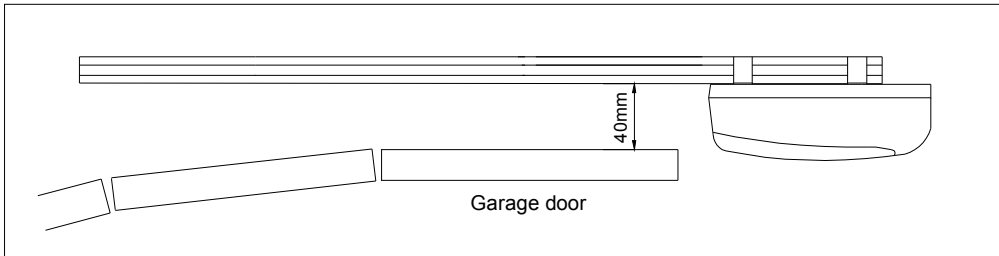

Fig.2

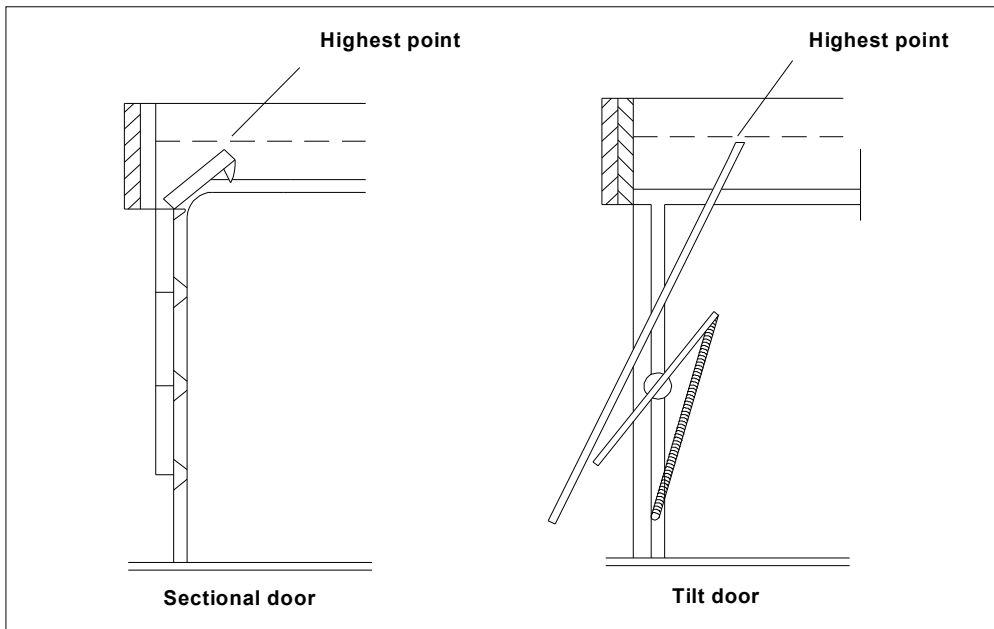

Fig.3

- Fit the header bracket to the wall above the door, the centerline of the door should align with the centerline of the bracket, The bottom edge of the bracket should align with the horizontal line. Fix the header bracket to the wall with expansion bolts.

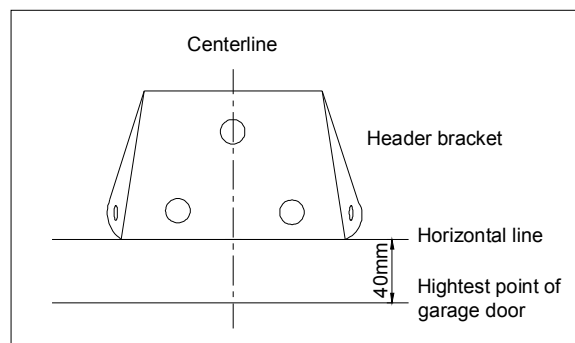

Fig.4

Step 2

- Insert the shuttle into the groove of the chain drive rail. Be sure it faces the right direction (the release arm on the shuttle towards the powerhead). Fasten the four screws (M6x22mm).

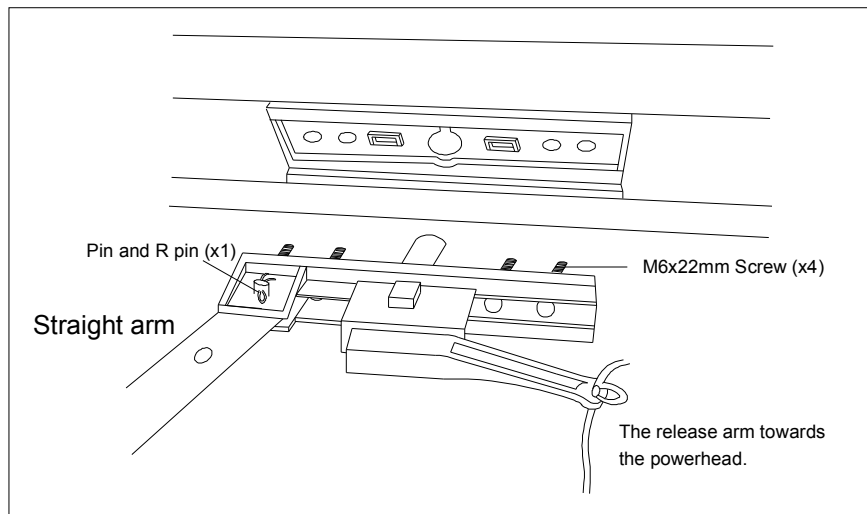

Fig.5

Step 3

- Place the powerhead on the floor, add cardboard packing to protect the powerhead from scratching by the floor. Attach the powerhead unit to the chain drive rail, make sure the spindle is inserted into the chain drive, then fix the brackets.

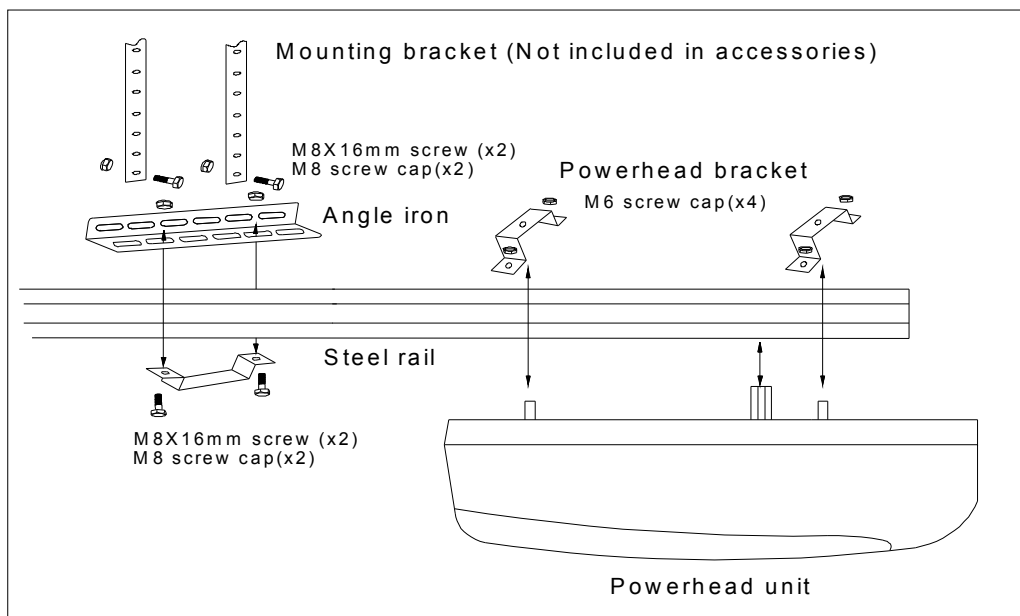

Fig.6

Step 4

- Close the door.
- Place the operator in the center of the floor. Lift the front end of the rail up to the header bracket that has been mounted above the garage door, insert the bolt and secure it with nut see Fig.7.

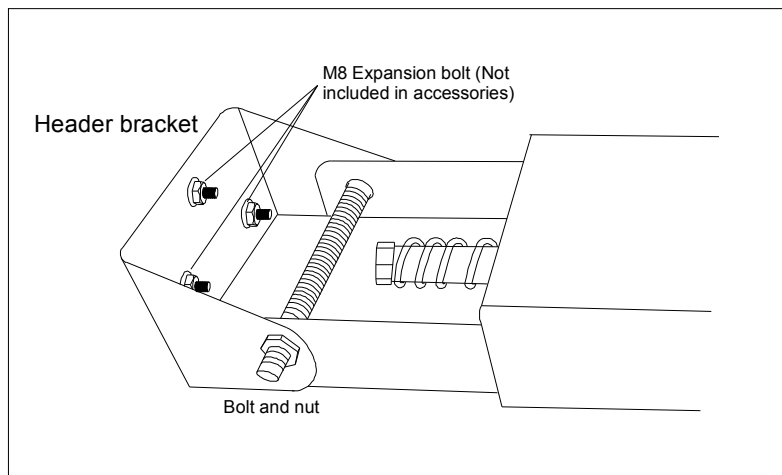

Fig.7

Step 5

- Raise and support the powerhead with a ladder and line up the rail with the centerline marked on the door. The rail must be level.
- Fix the rail to ceiling with mounting brackets (not included in accessories) and angle iron see Fig.6, make sure that the rail is level. If necessary, Check the door does not touch any part of the rail by opening or closing it manually.

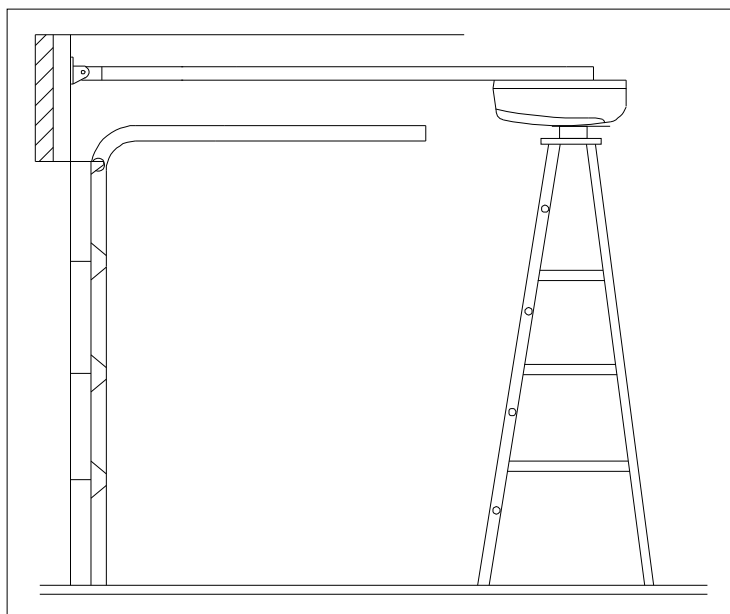

Fig.8

Step 6

Fix the door bracket on the top edge of the door with screws (M8X55) and screw caps (M8). Link the L arm to the door bracket with pin and R pin. Link the straight arm to the shuttle with pin and R pin, then connect L arm to straight arm with two screws (M8X16) and screw caps (M8), ensure the door arm can be moved freely. See Fig.8, Fig.9 and Fig.10.

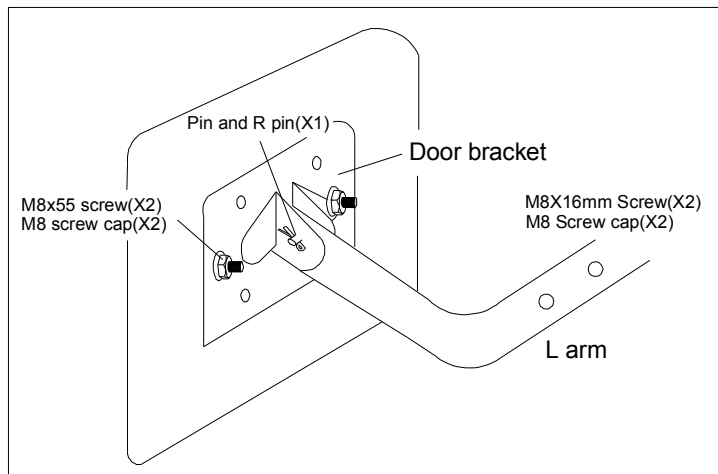

Fig.9

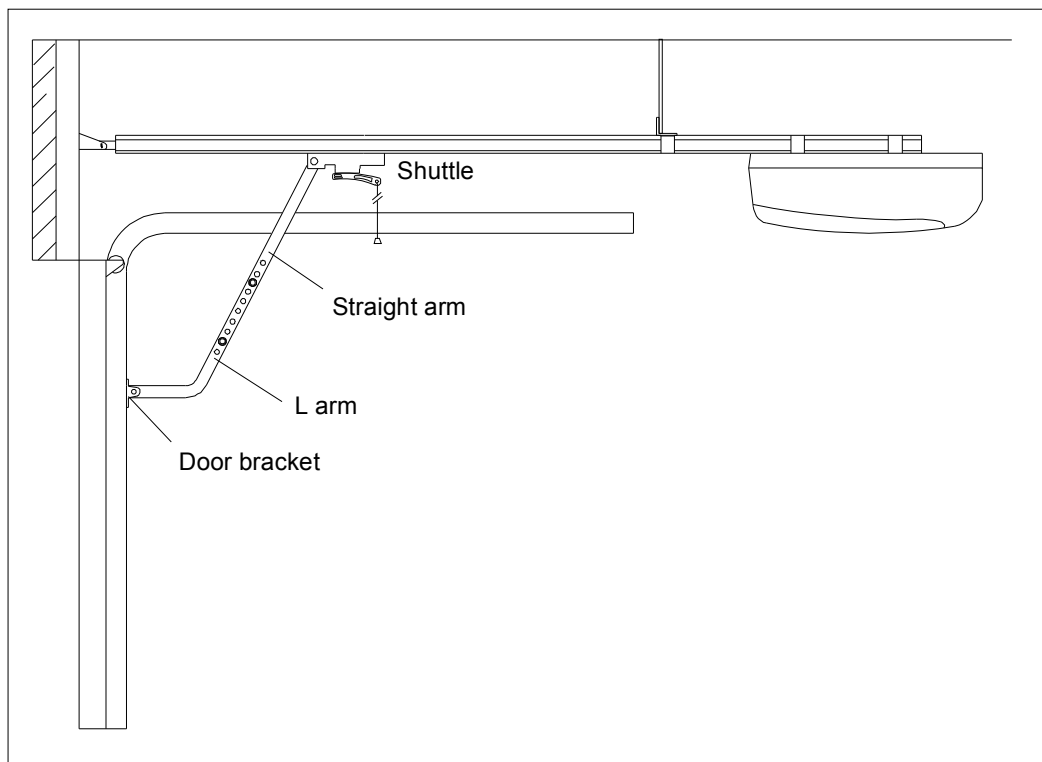

Fig.10

Manual operation

If the door has to be operated manually due to a power cut or malfunction of the automated system, pull the release rope, open and close the door manually. To reconnect the door, move the door by hand until it engages into the chain shuttle.

6. Programming

SET button: Mode set and Confirm function

CODE button: Transmitter code set and clear function

UP button: Up limit

DOWN button: Down limit

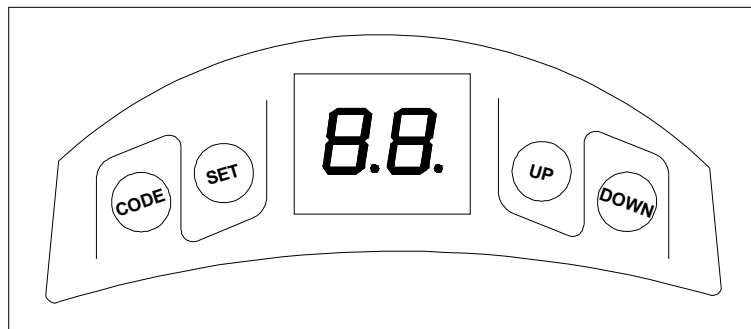

Fig.11

- With power on, the bulb will turn on about 2 seconds and then turn off. The LED will display number from '99' to '11', when '— —' appears on the LED display, the operator is now in normal state.

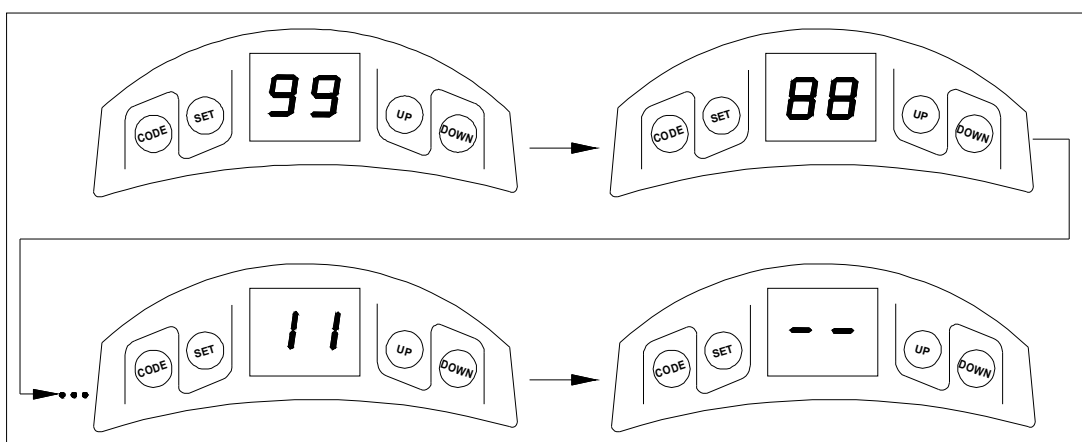

Fig.12

Transmitter

- Button 1, button 2, button 3: The remote control works in a single channel mode. With each press of the remote control button which has been programmed, the gate will open, stop, close or stop cycle.
- Button 4: LOCK button

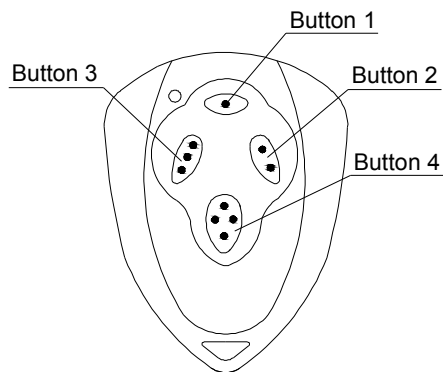

Fig.13

Adding extra transmitter (learn)

1. Press the **CODE**, 'Su' is indicated on the LED display.
 2. Press the transmitter button which you want to use (button 1, 2, 3), then press the same button again.
 3. 'Su' on the LED display will flash.
 4. '— —' is indicated on the LED display, then the learning process is finished.
- Up to 20 transmitters may be used.

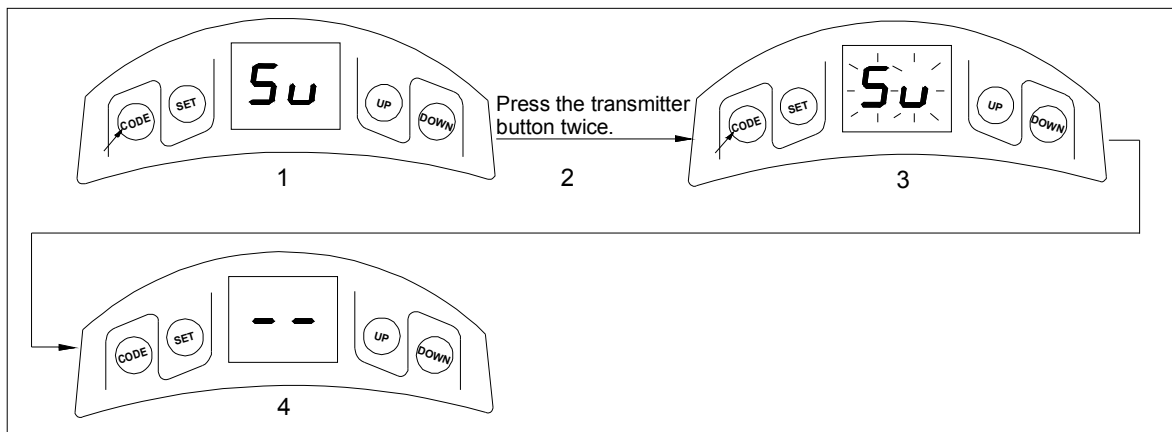

Fig.14

Deleting stored transmitters

1. Press and hold **CODE**, 'Su' is indicated on the LED display.
2. Do not release the button until 'dL' flashes.
3. '— —' is indicated on the LED display, this indicates that all stored transmitters have been deleted completely.

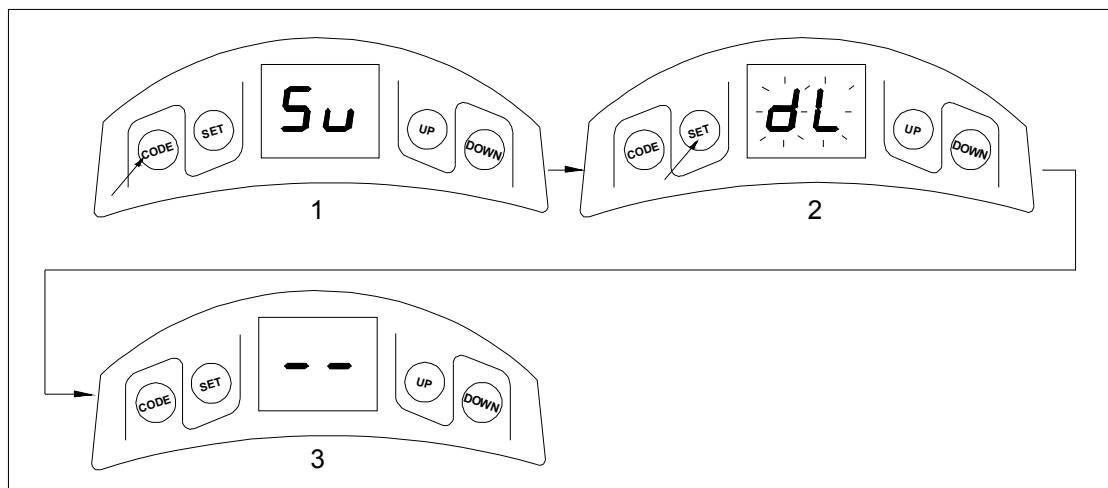

Fig.15

Open and Close limit

1. Press and hold **SET** four seconds until 'P1' is indicated on the LED display. The operator is now in programming mode.

2. Press SET again, 'OP' is indicated on the LED display.
3. Press and hold UP to set the open limit, 'OP' on the LED display will flash, release the button until the door has reached desired position.
4. Press SET to confirm the open limit position, the LED will now indicated the 'CL'.
5. Press and hold DOWN to set the close limit, 'CL' on the LED display will flash, release the button until the door has reached desired position.
6. Press SET to confirm the close limit position.
7. The door will now do a complete open & close cycle.

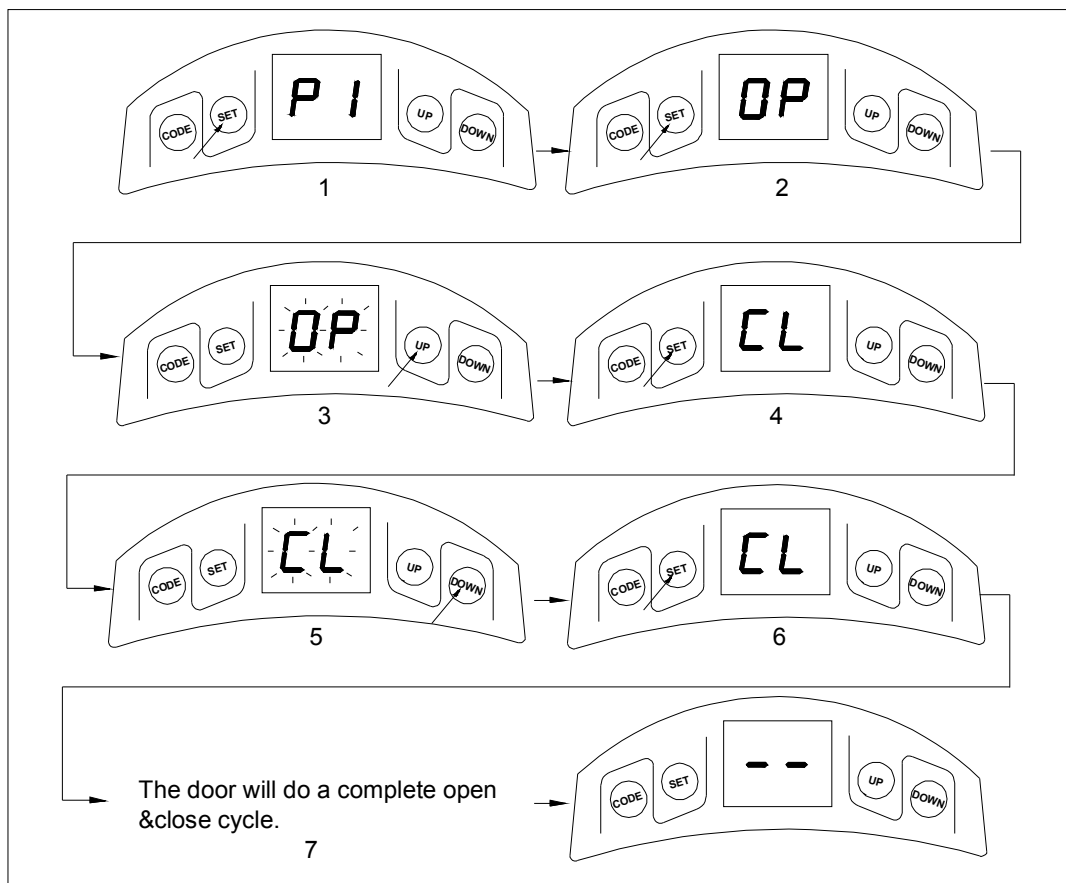

Fig.16

Adjusting obstruction force sensitivity

If the door meet an obstruction during closing, it will stop and reverse about 15cm~20cm.

1. Press and hold SET four seconds until 'P1' is indicated on the LED display.
2. Press UP button, 'P2' is indicated on the LED display.
3. Press the SET, the unit is now in force adjustment mode. Note: the factory preset is F5.
4. Press UP to increase force setting, maximum force setting is level 9 (F9). Press DOWN to decrease force, minimum force setting is level 1(F1).
5. Press SET to confirm.

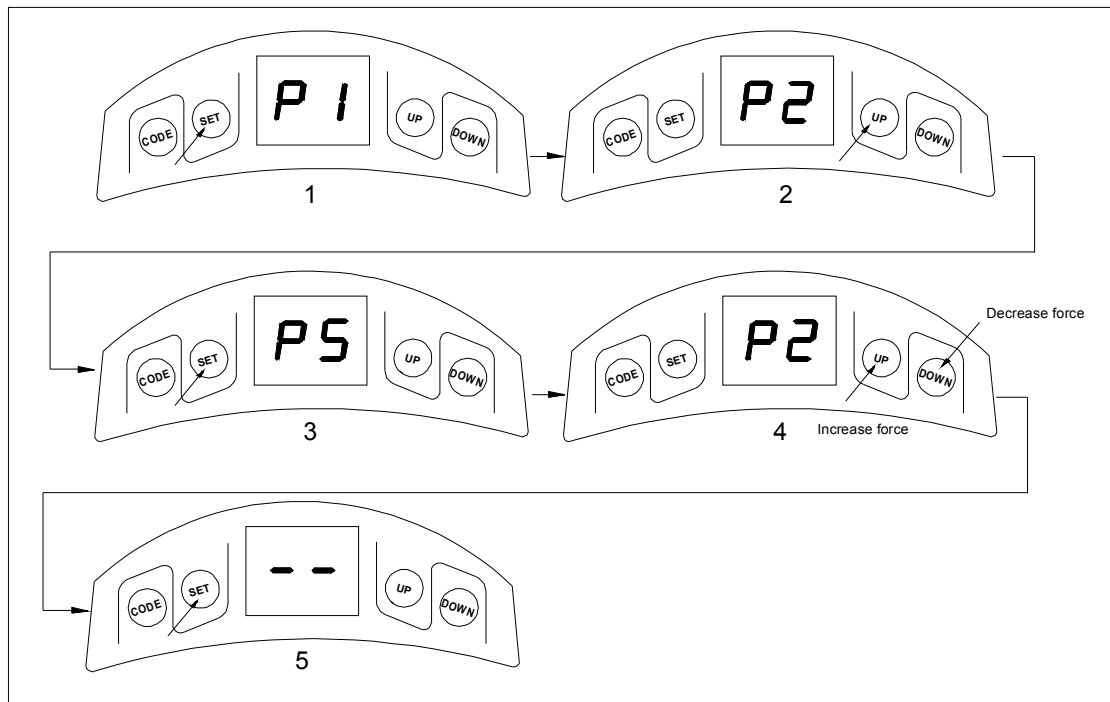

Fig.17

Infrared photocell

1. Press and hold SET four seconds until 'P1' is indicated on the LED display.
2. Press UP button twice until 'P3' is indicated on the LED display.
3. Press the SET. The factory preset is 'H0'.
4. Press UP ('H1' will display) to enable the photocell. Press DOWN ('H0' will display) to disable the photocell.
5. Press SET to confirm the setting.

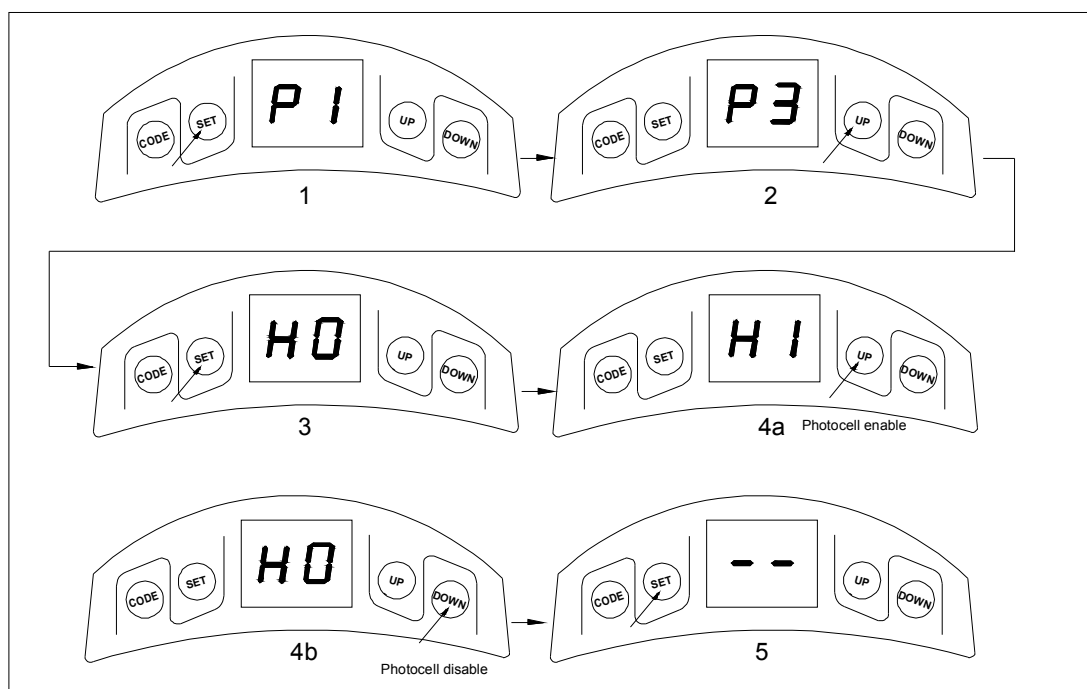

Fig.18

Automatic closing (1~9 minutes adjustable)

1. Press and hold SET four seconds until 'P1' is indicated on the LED display.
2. Press UP button three times until 'P4' is indicated on the LED display.
3. Press the SET. The factory preset is 'b0'.
4. Press UP or DOWN to set auto close time (b0-b9). Press UP to increase timer, press DOWN to decrease timer. Note: To disable auto close set timer to 'b0'.
5. Press SET to confirm the setting.

NOTE: Automatic closing is available only when the door is in fully opened position.

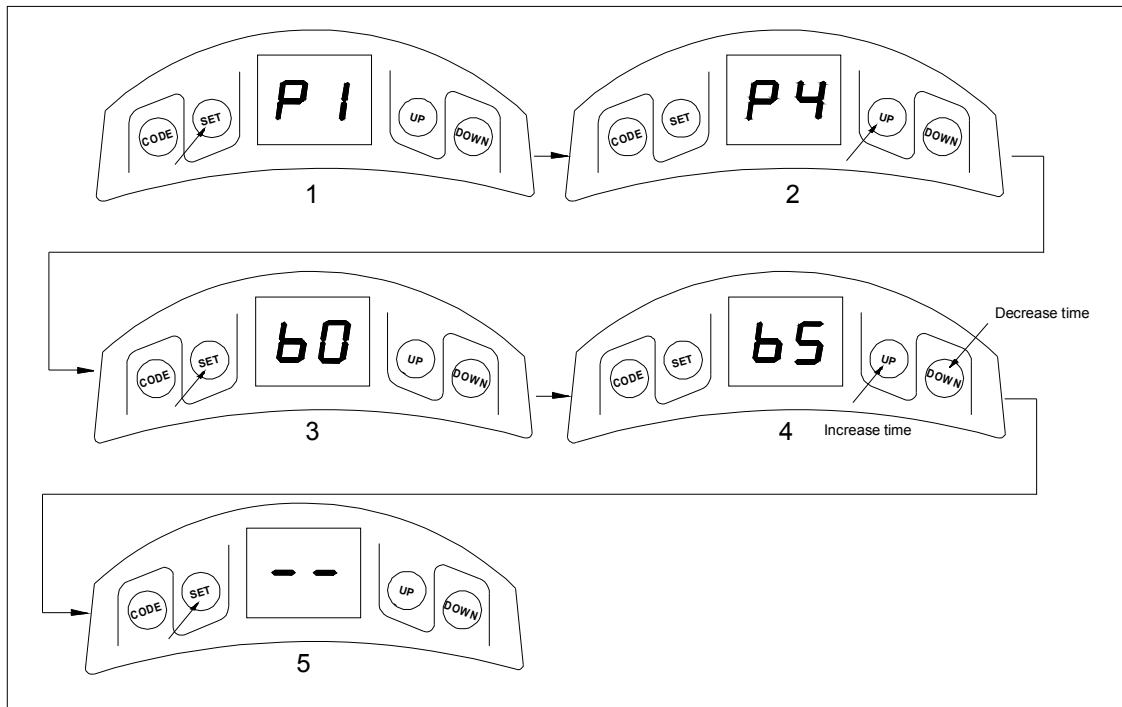

Fig.19

Door lock mode

1. Press and hold SET four seconds until 'P1' is indicated on the LED display.
2. Press UP button four times until 'P5' is indicated on the LED display.
3. Press the SET. The factory preset is 'UL'.
4. Press UP to enable the door lock ('LC' will display). Press DOWN to disable to door lock ('UL' will display).
5. Press SET to confirm the setting.

NOTE: LOCK function is available only when the door is in fully closed position.

After setting Door LOCK function, the transmitter locked, you need press button 4 of transmitter to unlock, then press the other buttons to operate the door.

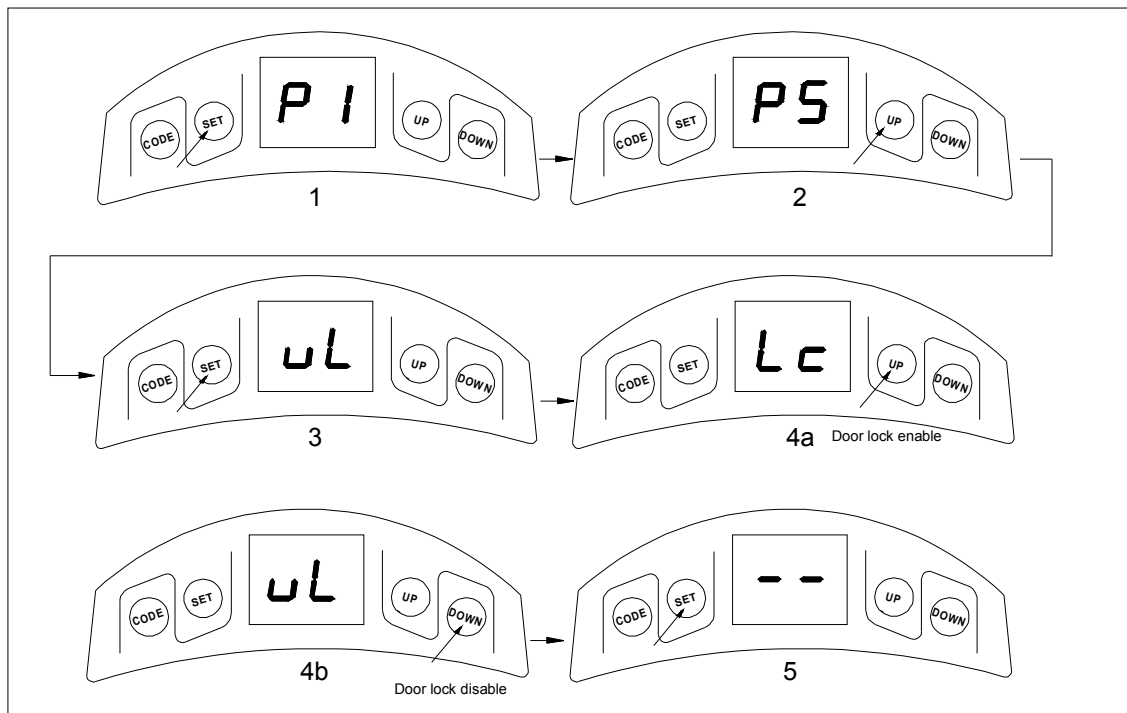

Fig.20

7. External terminal connections

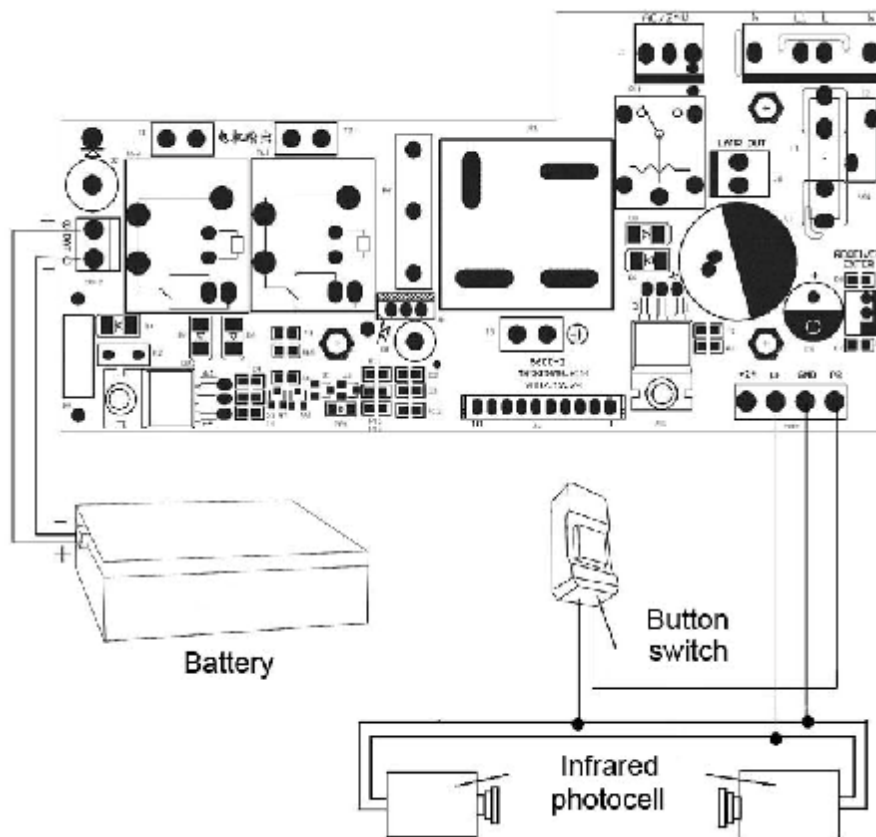

Fig.21

8. Maintenance

- Check the door once a month. The door should be carefully checked for balance. The door must be in good working order.
- Check and add lubricant regularly.
- The auto-reverse function should be regularly inspected, and adjusted if necessary. For service, call an experienced serviceman.
- We suggest for safety reasons, photocells be used on all doors.
- Disconnect from mains supply before replacing bulb.
- Be sure to read the entire manual before attempting to perform any installation or service to the door operator.

9. Troubleshooting

Trouble	Possible causes	Solutions
The door fails to open and close. LED display does not light.	1. Power is OFF 2. Fuse blown	1. Make sure that power is ON. 2. Replace fuse.
After program the open and close limit, the motor fails to work.	Open and close limit	Reprogram the open and close limit.
The door can open, fails to close.	1. Infrared beam is obstructed. 2. Infrared photocell function is enable, but the photocell has not been installed.	1. Remove obstructions. 2. Make sure the infrared photocell function is disable.
Remote control does not work.	1. Battery level may be low. 2. Transmitter	1. Replace the battery inside the transmitter. 2. Re-program the transmitter.
The transmitter operating distance becomes short or indicator light on the transmitter begins to dim.	Battery level may be low.	Replace battery.